



# Installation & Operation Manual



**Calibration Instructions**

- 1) Vehicle must be leveled. For best results, calibrate with a load that is within 1,000 LBS (450 KG) of the legal weight limit for the axle group. Do Not Calibrate Empty!
- 2) Using a level and spirit level, confirm level for the axle group placed. Make sure vehicle does not roll. Check to the Right Weigh load scale.
- 3) Park on level surface with the brakes off. Make sure vehicle does not roll. Check wheels, if needed.
- 4) Allow enough time for the vehicle Control Valve (CV) to fully purge the air lines. (This may take several minutes depending on the type of CV)
- 5) Allow enough time for the vehicle Control Valve (CV) to fully purge the air lines. (This may take several minutes depending on the type of CV)
- 6) With the load scale mounted to the vehicle, level the vehicle and set the scale on the scale base and the scale.

**Calibration Log** Complete the numbers of the Right Weigh load scale with a weight in the ground scale of load scale when it is empty. No calibration is needed.

Calibration Date	Calibration Scale	Calibration CV	Calibration CV

**Operating Instructions**

- 1) Park on level surface with the brakes off. Make sure vehicle does not roll. Check wheels, if needed.
- 2) Allow enough time for the vehicle Control Valve (CV) to fully purge the air lines. (This may take several minutes depending on the type of CV)
- 3) Read the Right Weigh load scale on the ground scale and the scale.

Warning: Never use the scale on uneven ground, uneven surfaces, or on any surface that is not level. The scale must be used on a level surface. Please contact Right Weigh, Inc. for additional assistance. Please contact Right Weigh, Inc. for additional assistance. Please contact Right Weigh, Inc. for additional assistance. Please contact Right Weigh, Inc. for additional assistance.

For additional assistance, please contact Right Weigh, Inc. at 800-858-2299.

## ONBOARD LOAD SCALE EXTERIOR ANALOG | 310-M3 Series

Thank you for choosing to drive more and scale less! Here at Right Weigh, we are committed to making our products simple to install and easy to use. We understand that installation can vary between vehicles and yours may not be described in this manual. In any event, our technical support team is ready to answer your questions!



(503) 628-0838  
(888) 818-2058 - Toll Free (USA ONLY)



[support@rwls.com](mailto:support@rwls.com)



[www.rwls.com/how-to-calibrate-install/](http://www.rwls.com/how-to-calibrate-install/)

## IMPORTANT!

Please read instructions **COMPLETELY** and thoroughly before installation. Right Weigh, Inc. is not responsible or liable for product failure or vehicle damage due to improper installation. The installation requirements are outlined in this manual and should be followed thoroughly to avoid inaccuracy or damage to the product.

It is also important to be aware of vehicle manufacturer policies before making modifications to the vehicle. Right Weigh, Inc. is not liable or responsible for issues regarding warranties with other manufacturers. This is the responsibility of the customer. If you are unsure about how these installation practices apply to your vehicle, please contact your vehicle or component manufacturer.

FOLLOW US!



Parts Required	4
Specifications & Overview	5
Scale Installation	6
Calibration and Operation	8
Troubleshooting	9
Warranty Statement	10
Return Policy & Repairs	11

# PARTS REQUIRED

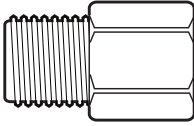

**1/4 NPT Female to 1/4 NPT Male Brass Adaptor Included**

These parts are sold separately in the 101-SK kit (two of these kits will be required to complete installation):

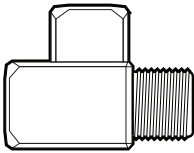

**Street Tee Fitting**  
The thread size and type should match the thread size and type of the vehicle suspension

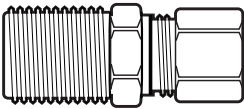

**Male NPT Tube for 1/4" Air Line**  
The thread size and type should match the thread size and type of the vehicle suspension

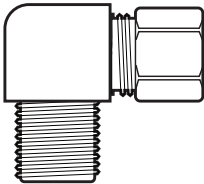

**Male Elbow Tube Fitting for 1/4" Air Line**  
Tubing size to match the male straight air line fitting. 1/4" NPT to match the thread size of the fitting at the bottom of the load scale

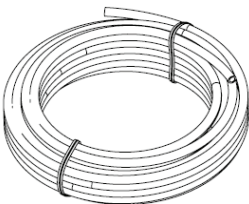

**1/4" Air Line**  
The amount of air line needed depends on the mounting location of the gauge

## Technical Specifications

Operating/Storage Temperature: -40° F to +185° F (-40° C to +85° C)

Enclosure: Black Polypropylene

Gauge Size: 3.5"

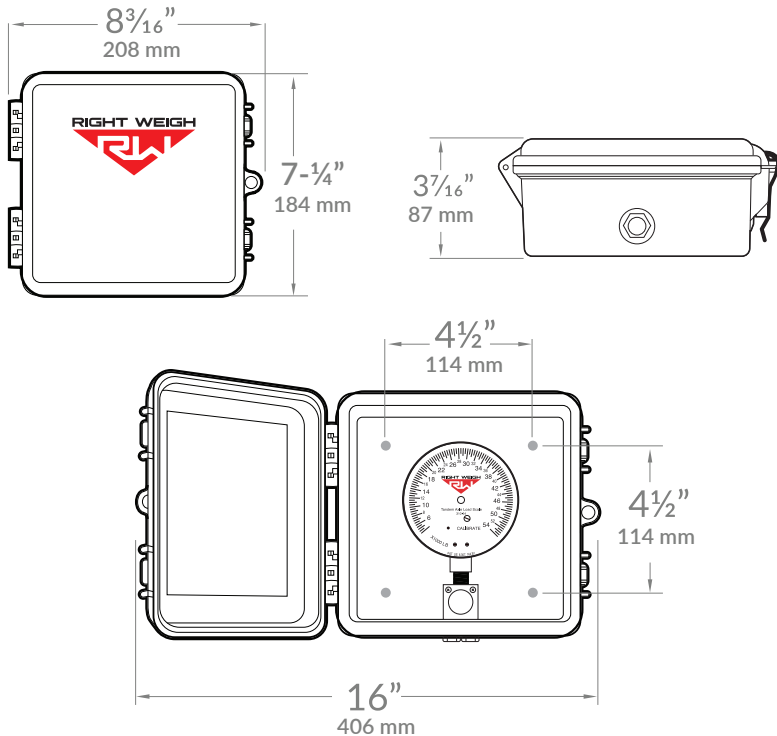

The 310-M3 series is designed for use on an air suspension axle group with a two height control valves. Within this series, there are different products designed for different axle group configurations. Before installation, make sure you have the proper gauge for your application:

Suspension	Gauge - Pounds (LBS)	Gauge - Kilograms (KG)
Single Axle	310-30-M3	310-16KG-M3
Tandem Axle	310-54-M3	310-25KG-M3
Tri Axle	310-80-M3	310-30KG-M3

If you have the wrong gauge for your application, please call our technical support listed on page 2.

# SCALE INSTALLATION



The 310 Series gauge comes in a protective box with a mounting bracket and hardware. The following steps will walk you through how to correctly mount and install the scale. Be sure to choose a location that is easily accessible and safe from potential damage (forklift posts, tire caps, etc.)

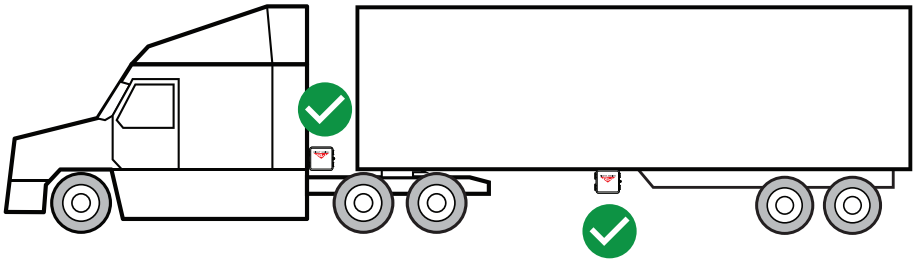

**DO NOT** mount the scale directly to the chassis or any other main beam unless it is approved by the vehicle manufacturer. Doing so may void the warranty with the vehicle manufacturer.

## 1 MOUNT SCALE

Choose a location to mount the scale that is easily accessible and safe from potential damage (forklift posts, tire caps, etc.). Mount the bracket in the chosen location using two bolts to secure it. Install the gauge box to the bracket using supplied hardware.

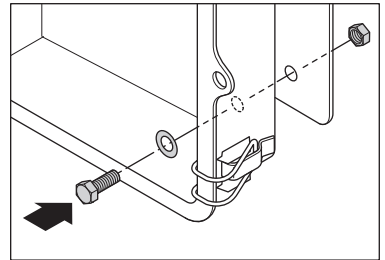

Make sure to use **BOTH** supplied mounting bolts to secure the bracket to the vehicle. Using only one bolt can result in a cracked bracket and the scale falling off the vehicle.

## 2 DUMP AIR FROM SUSPENSION SYSTEM

### 3 TEE INTO AIR SUSPENSION

Remove the suspension air line fitting from the top of one of the air bags connected to the first height control valve. Insert a street tee fitting into the top of the air bag that matches the thread size of the vehicle suspension. Reinstall the suspension air line and fitting into the street tee. For more information on the parts needed for air line installation, see page 4.

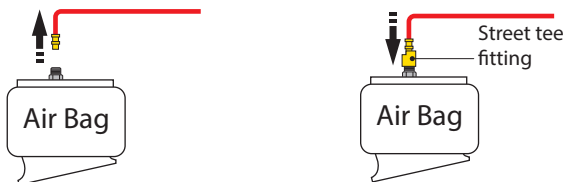

### 4 INSTALL NEW 1/4" AIR LINE & FITTING

Install a new 1/4" air line and fitting into the remaining port on the tee.



### 5 REPEAT STEPS 3/4

Repeat steps 3 and 4 on an air bag attached to the second height control valve.

### 6 ROUTE AIR LINE TO GAUGE

Route the new 1/4" air line from both tee fitting assemblies to the gauge. Secure air line with zip ties.

### 7 INSTALL GAUGE FITTINGS

Install and tighten one elbow fitting into one of the fittings on the bottom of the gauge. Install adaptor fitting included onto the other fitting on the bottom of the gauge and install the other elbow fitting underneath as shown. Install airline from each air bag into the fittings and tighten completely.

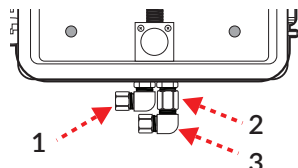

### 8 AIR UP SUSPENSION SYSTEM

Check for leaks and that all fitting connections are secure. Pull red push/pull valve to check that air pressure is getting to the gauge.

## CALIBRATING

- 1: The vehicle must be fully loaded. For best results, calibrate with a loaded weight within 1500lbs or 750kgs of your typical axle group weight (DO NOT calibrate empty!)
- 2: Using a certified in-ground scale, obtain a loaded weight for the axle group attached to the gauge.
- 3: Park on a level surface. Shift the transmission to neutral and set the parking brakes.
- 4: Chock the wheels to prevent unexpected vehicle movement.
- 5: Release the parking brakes.
- 6: Make sure the Height Control Valves (HCVs) have fully inflated the air bags. If needed, briefly dump the air from the suspension and allow the HCVs to refill the system.
- 7: Pull the red push/pull valve so that it is in the fully open position.
- 8: Using a flathead screwdriver, turn the calibration screw on the dial face until the gauge matches the certified axle group weight.

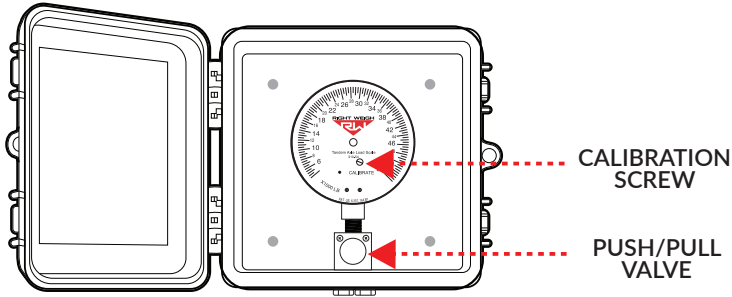

## OPERATING AND WEIGHING

- 1: Park on a level surface. Shift the transmission to neutral and set the parking brakes.
- 2: Chock the wheels to prevent unexpected vehicle movement. Release the parking brakes.
- 3: Make sure the Height Control Valves (HCVs) have fully inflated the air bags. If needed, briefly dump the air from the suspension and allow the HCVs to refill the system.
- 4: Pull the red push/pull valve so that it is in the fully open position. View the load scale to determine the on-the-ground axle group weight.
- 5: Push the push/pull valve so that it is in the full closed position.



PROBLEM	CAUSE	SOLUTION
<p>Erratic / Inaccurate Weight Readings</p>	<p>The vehicle is not parked on a level surface</p>	<p>Park on level concrete ground. Parking on sloped or banked surfaces will cause the vehicle weight distribution to shift between the axle groups. Additionally, if one or more of the vehicle's wheels are in a pothole, that could result in additional pressure or torque on the suspension air bags. This will cause the suspension to have a different air pressure than what is normally needed to hold up the given weight.</p>
	<p>The vehicle's brakes are on</p>	<p>Release the parking brakes when weighing and/or calibrating. When the vehicle brakes are set, they could apply additional pressure or torque on the suspension air bags. This will cause the suspension to have a different air pressure than what is normally needed to hold up the given weight.</p>
	<p>There is a significant air leak in the suspension system</p>	<p>Check air lines for leaks. Having a leak could cause the HCV to refill the suspension at regular intervals to maintain the vehicle's ride height. If there is a significant leak, the gauge display will slowly decrease in value and then quickly increase in value when the HCV refills the suspension system.</p>
	<p>The Height Control Valve (HCV) is malfunctioning or broken</p>	<p>If the HCV is not functioning correctly, the air pressure applied to the suspension system could be inconsistent and/or erratic. To test for an HCV problem, acquire a weight reading from the Right Weigh gauge and write it down (refer to gauge operating instructions for proper procedure). Drive the vehicle around the block and return to the same location. Acquire a second reading from the Right Weigh gauge. If the two readings are significantly different, then the HCV might be malfunctioning.</p>



Right Weigh is committed to providing quality products that function as intended, and we always stand behind our workmanship. Our industry leading warranty is our best effort to express this commitment. Products manufactured or sold by Right Weigh, Inc. are warranted to be free from significant defects in material and workmanship 3 years from date of purchase. During this time, and within the boundaries set forth in this warranty statement, Right Weigh, Inc. will, at its sole discretion, correct the product problem or replace the product.

This warranty shall not apply to product problems resulting from: (1) Improper application, installation, incorrect wiring, or operation outside of the approved specifications of the product. (2) Accidents, faulty suspension parts or power surges (3) Inadequate maintenance or preparation by the buyer or user (4) Abuse, misuse, or unauthorized modification. (5) Acts of God, lightning strike, floods, fire, earthquake, etc.

Right Weigh, Inc. assumes no responsibility or liability for any loss or damages resulting from use of Right Weigh, Inc. products.

In no event shall Right Weigh, Inc. be liable for direct, indirect, special, incidental or consequential damages (including loss of profits or loss of time) resulting from the performance of a Right Weigh, Inc. product. In all cases, Right Weigh, Inc. liability will be limited to the original cost of the product in question. Right Weigh, Inc. reserves the right to make improvements in design, construction, and appearance of products without notice.

## Return Policy and Authorization

Before returning any product, please obtain a Return Merchandise Authorization number (RMA#) by calling Customer Service at 503-628-0838 or e-mailing support@rwls.com. Include the RMA# and information regarding the reason for the return with the returned product. Shipping costs for returns must be prepaid by the customer. For your protection, items must be carefully packed to prevent damage in shipment and insured against possible damage or loss. Right Weigh, Inc. will not be responsible for damage resulting from careless or insufficient packing or loss in transit.

An RMA# must be obtained by the original purchaser before any product can be returned. Only new, unused products may be returned. Installed, used, damaged, modified or customized products can not be returned for credit. Credit will be issued to the original purchaser after evaluation by Right Weigh, Inc.

## Repairs/Replacements

An RMA# must be obtained before any product can be returned. Right Weigh, Inc. will evaluate returned products at no charge. If Right Weigh, Inc. determines that the returned product is under warranty it will repair the product or parts thereof at no charge, or if unrepairable, replace it with the same or functionally equivalent product whenever possible. Right Weigh, Inc. will return the product at its expense via a shipping method (carrier to be at sole discretion of Right Weigh, Inc.) equal to or faster than the method used by the customer. Products or parts thereof not covered by warranty will be repaired or replaced at customer expense upon authorization by the customer. Right Weigh, Inc. will return the repaired product at customer expense via a shipping method (carrier to be at sole discretion of Right Weigh, Inc.) equal to or faster than the method used by the customer.

For additional support contact:

Right Weigh, Inc.

(503) 628-0838

(888) 818-2058 - Toll Free (USA ONLY)

[www.rwls.com](http://www.rwls.com)

[support@rwls.com](mailto:support@rwls.com)



Right Weigh, Inc.  
Hillsboro, Oregon USA

PP-003-0013 Revision D

September 2020

©2015-2020 Right Weigh, Inc. All rights reserved.