

# Right Weigh Load Scales

201-BR

Right Weigh Interior Bracket for 201 Series  
Assembly Instructions

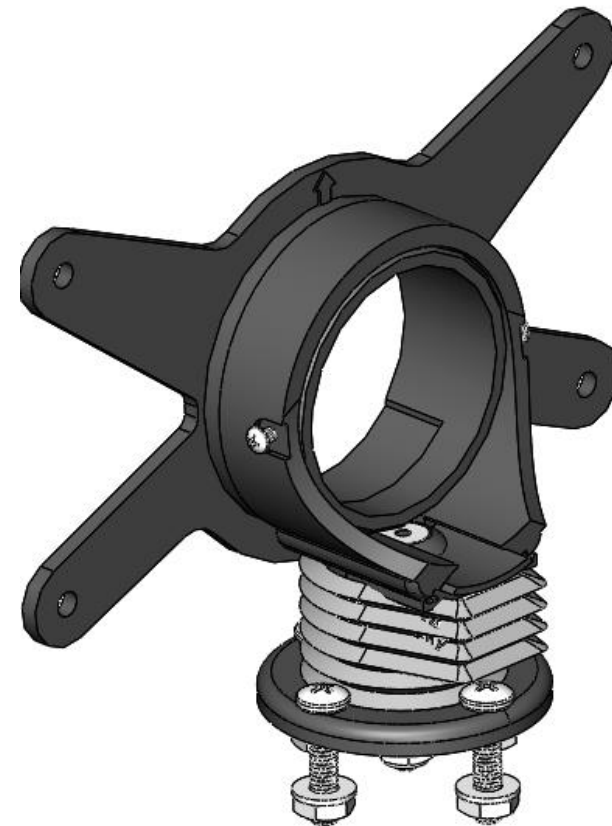

Right Weigh  
Load Scales

PP-003-0033 Rev A

December 2018

**Right Weigh, Inc.**

Hillsboro, Oregon, USA

[www.rwls.com](http://www.rwls.com)

©2018 Right Weigh, Inc. All rights reserved.

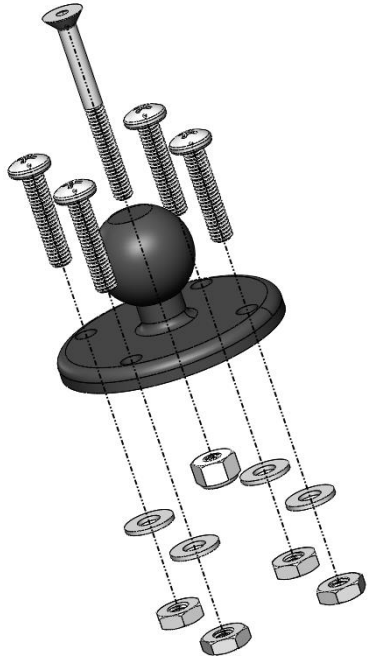

1. Choose a mounting location in your vehicle that permits routing of air lines and electrical connections to the gauge
2. Mount the base to the vehicle using any combination of the supplied hardware

3. Assemble the slide into the bottom of the ring. Put the hose clamp and rubber boot over the assembly but do not tighten the hose clamp yet
4. The ring assembly should now snap over the ball. You may have to loosen the hose clamp slightly to allow it to snap over the ball.

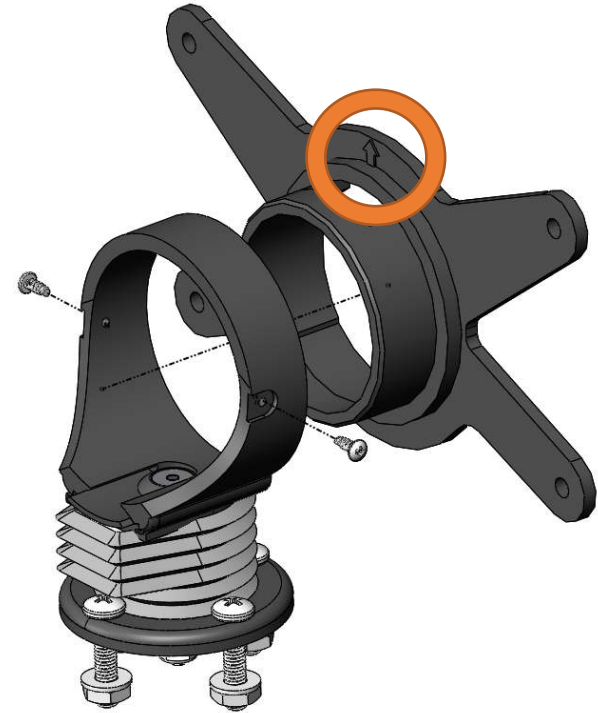
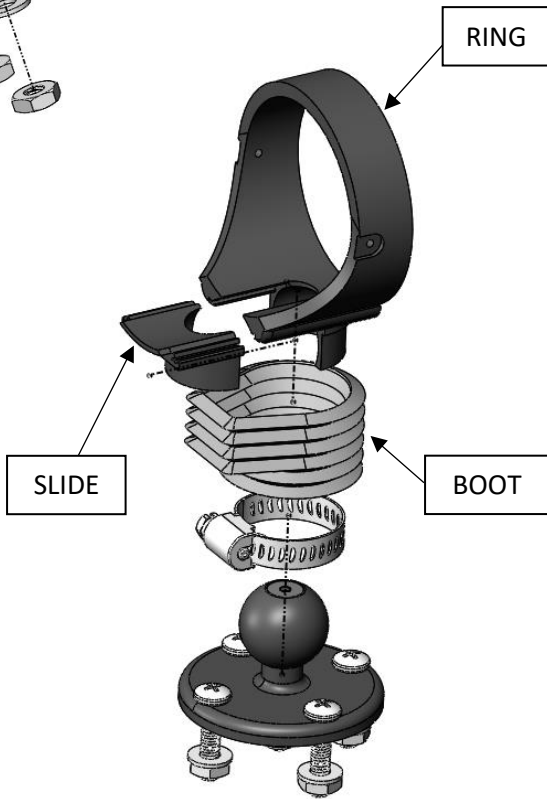

5. Install the gauge adapter into the ring and hold down using the 2 small screws on the side. Make sure that the up arrow on the back of the bracket, corresponds with the top of the gauge.
6. Following the instructions that came with your gauge, connect any electrical and/or air lines and attach the gauge to the bracket.