

RIGHT WEIGH



Installation Manual



STRAIN SENSOR EPOXY KIT

FOR STEER AXLES | 221-SK

Thank you for choosing to drive more and scale less! Here at Right Weigh, we are committed to making our products simple to install and easy to use. We understand that installation can vary between vehicles and yours may not be described in this manual. In any event, our technical support team is ready to answer your questions!



(503) 628-0838
(888) 818-2058 - Toll Free (USA ONLY)



support@rwls.com



www.rwls.com/manuals-resources/

IMPORTANT!

Please read instructions COMPLETELY and thoroughly before installation. Right Weigh, Inc. is not responsible or liable for any negative consequences as a result of improper installation or operation, including but not limited to product failure, or damage that could affect the integrity of the vehicle. The installation steps in this manual are for the sole use of trained installers. Right Weigh, Inc. accepts no responsibility or liability for issues involving, but not limited to, incorrect installation that occur from misinterpretation of the steps outlined in this document.

It is the end user's responsibility to be aware of vehicle manufacturer policies before making modifications to the vehicle. Right Weigh, Inc. is not liable or responsible for issues regarding, but not limited to, warranties with other manufacturers. This is the responsibility of the end user. For a more detailed explanation of the the warranty and liability of Right Weigh, Inc. please refer to the "Warranty Statement" and "Return Policy & Repairs" section of this document and www.rwls.com/warranty.

FOLLOW US!



Parts Included	4
Tools Required	6
How It Works	7
Installation Instructions	8
Axle Preparation	8
Applying Epoxy	9
Epoxy Jig Assembly	10
Tension Bar	11
Pickup Coil & Metal Cover	12
Connect To Scale	13
Warranty	14
Return Policy & Repairs	15

PARTS INCLUDED

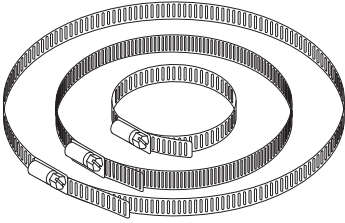

4 x Worm Drive Hose Clamps
(1 large, 2 medium, 1 small)

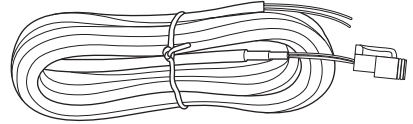

Extension Cable (25')

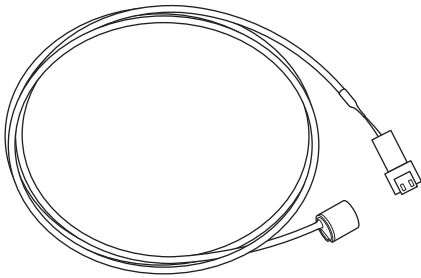

Pick-Up Coil
RW #EL-004-0054

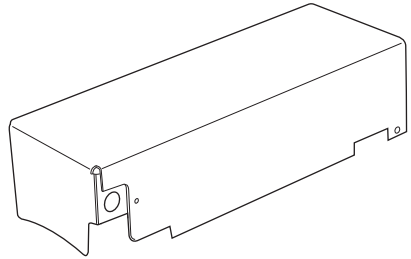

Metal Cover
RW #HW-010-0047

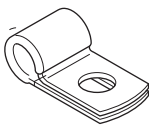

Loop Clamp



Bolt



Washer

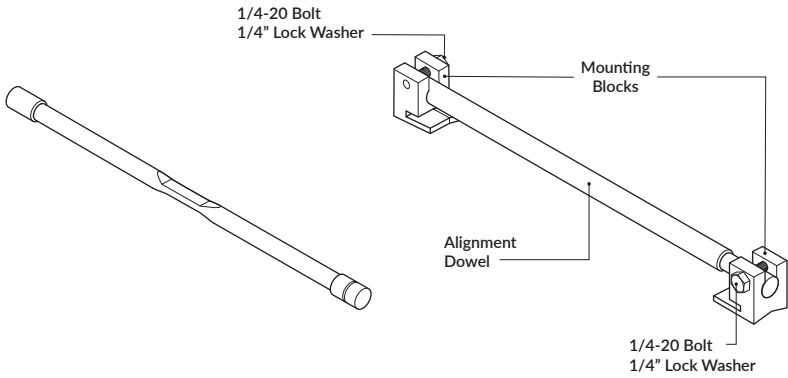

Tension Bar
RW #EL-001-0002

Epoxy Jig Assembly

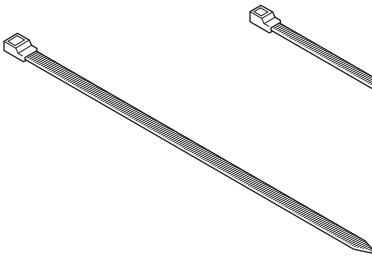

7" Cable Ties

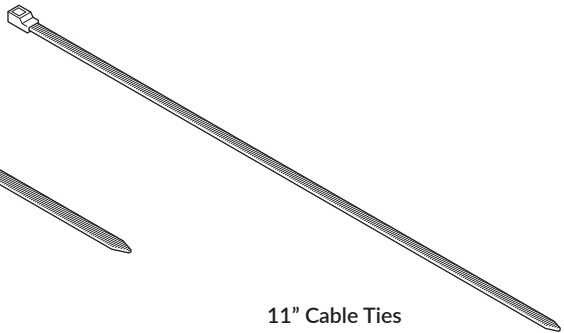

11" Cable Ties

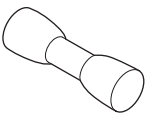

2 x Butt Connectors

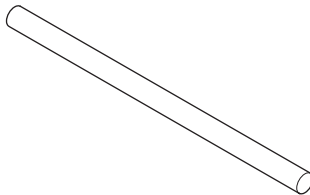

1 x Heat Shrink

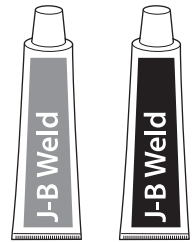

J-B Weld

TOOLS REQUIRED

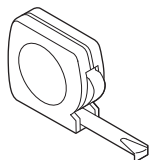

Tape Measure

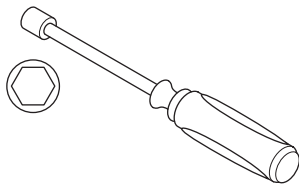

Nut Drivers
1/4" and 5/16"

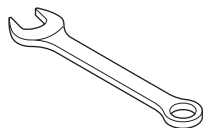

7/16" Wrench

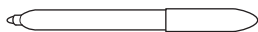

Marker

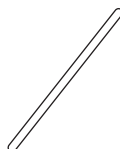

Stirring Stick
for Epoxy

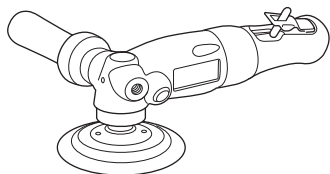

Angle Grinder
or Sander

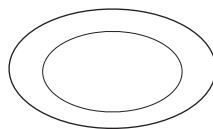

Paper Plate

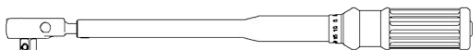

Torque Wrench

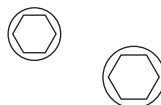

Sockets
5/16" and 7/16"

The sensor is mounted so that it compresses or extends as the axle bends. The change in length of the sensor is measured and converted to weight by the Right Weigh gauge after calibration.

EMPTY

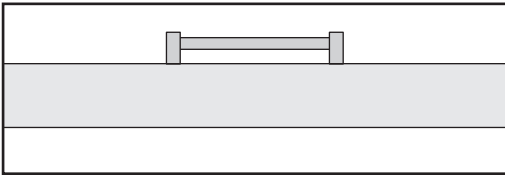

LOADED

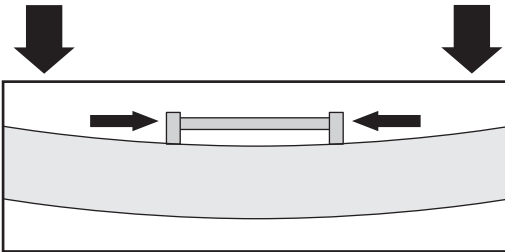

The tension bar is a wear item, whose life span depends on environmental conditions and severity of use. Replacement of this part is included with your 3 year warranty, after which time it can be purchased separately.

1 MARK THE CENTER OF THE AXLE

Use the tape measure to find the center of the axle. Mark the center line with a marker.



The sensor must be placed on the TOP of the axle

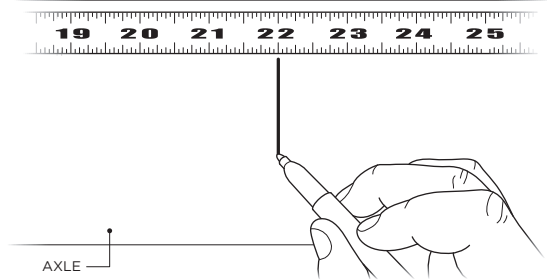

2 MARK MOUNTING BLOCK LOCATIONS

Place the Epoxy Jig Assembly on the axle so that it is centered over the axle center line. Draw circles around each mounting block to mark their location on the axle. Remove the jig from the axle when finished.

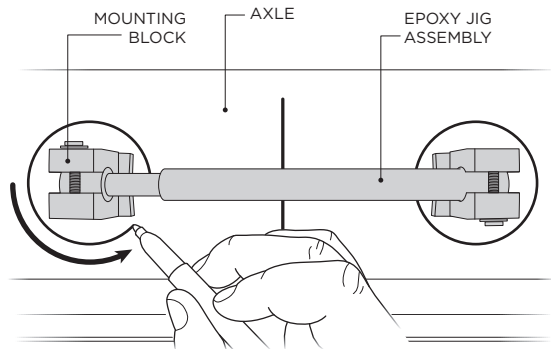

3 PREP AXLE FOR EPOXY

Use the angle grinder or sander to clean the axle in the circled areas to be epoxied. Make sure the area is free of paint, dirt, rust, and any other debris. Surface must be rough to promote good adhesion. Use 40 grit sandpaper or equivalent.

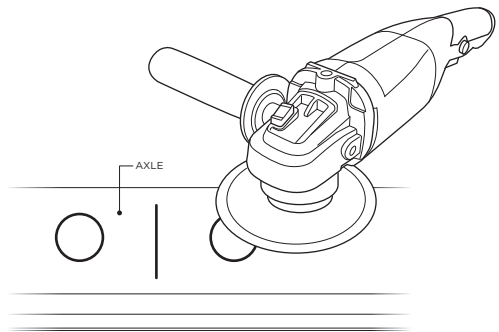

4 PREP EPOXY JIG FOR INSTALL

Place the Epoxy Jig on the axle, offset from the marked install location, so it's ready to be positioned in the epoxy. Take 2 medium hose clamps and wrap them over the bottom edge of the epoxy blocks and around the axle loosely.

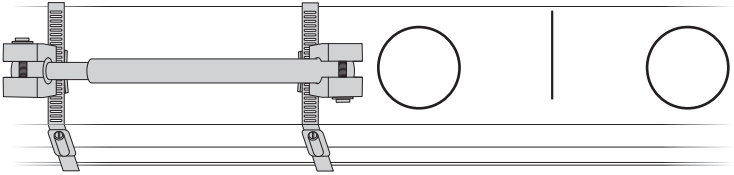

5 MIX EPOXY

Mix J-B Weld two part epoxy evenly in a 1:1 ratio.

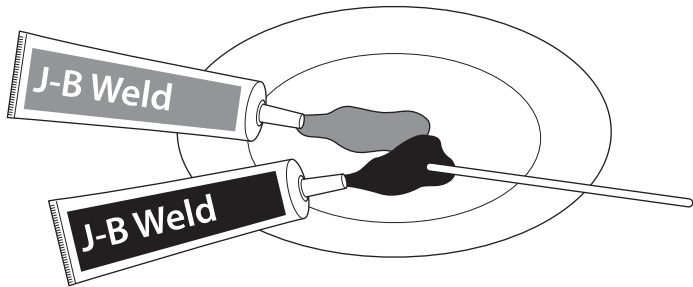

6 SPREAD EPOXY ON AXLE

Liberal spread the mixed epoxy over the marked areas where the mounting blocks will be placed.

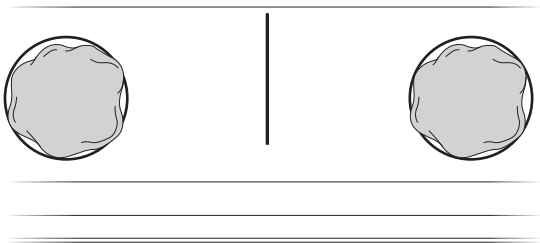

7 POSITION JIG ONTO EPOXY

Position the Epoxy Jig on the axle center line so that the mounting blocks are seated in the pools of epoxy. Tighten the two hose clamps to secure the jig in place. Torque each clamp to 80 in-lbs.

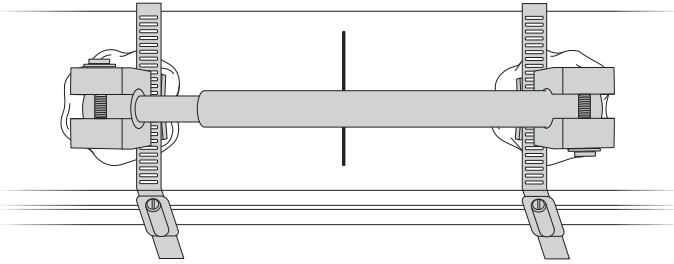

8 WAIT 24 HOURS FOR EPOXY TO CURE



The vehicle must remain parked for 24 hours while the epoxy cures. Failure to follow this guideline may result in poor adhesion and inaccurate weight readings.

9 REMOVE ALIGNMENT DOWEL

Loosen the mounting block bolts and remove the alignment dowel.

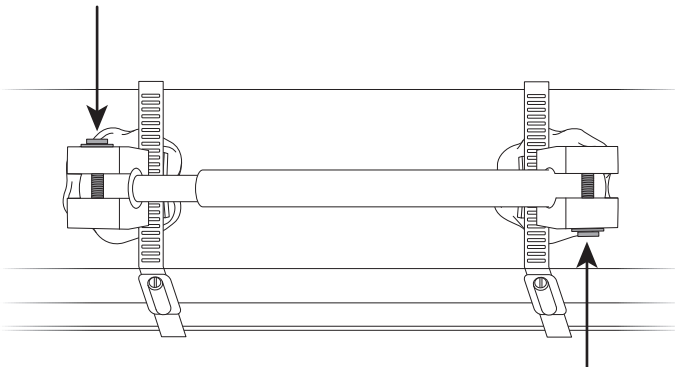

10 INSTALL TENSION BAR

Carefully install the tension bar into the mounting blocks.

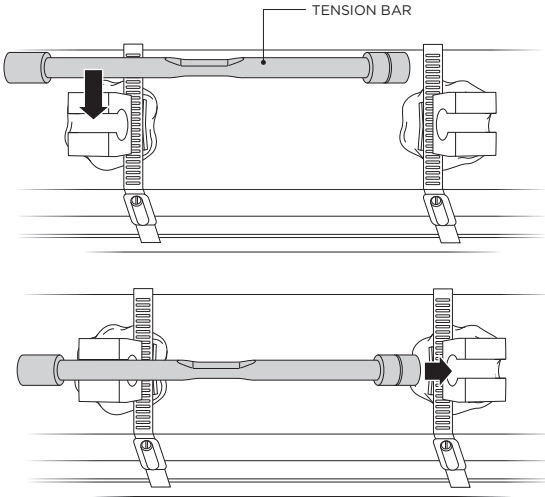

11 TIGHTEN MOUNTING BLOCK BOLTS

Tighten both mounting block bolts to clamp the tension bar in place. Torque each bolt to 10 ft-lbs.

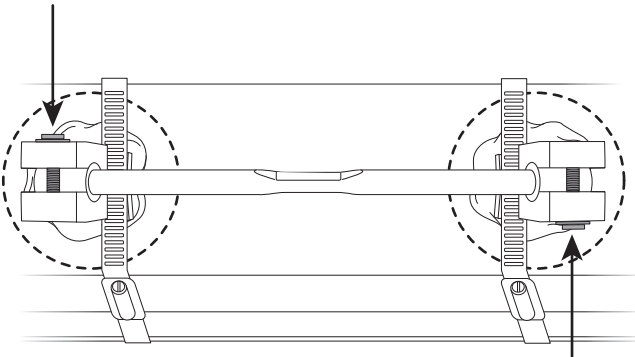

12 INSTALL PICKUP COIL AND CLAMP

Install pickup coil over the tension bar so that the cable points in desired direction on the axle. Use the small hose clamp to clamp the pickup coil in place. Use a nut driver to tighten the clamp.

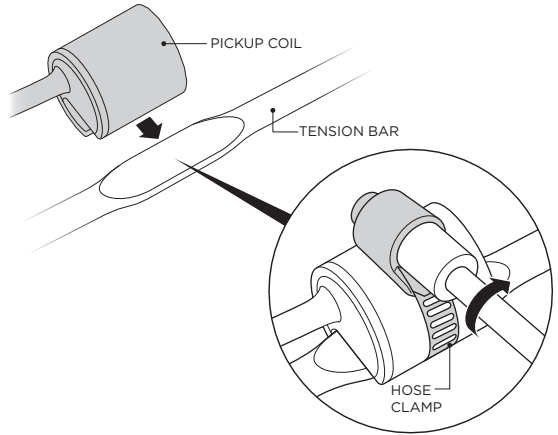

13 INSTALL METAL COVER

Center the cover over the tension bar assembly and secure in place using the large hose clamp. For best results torque the hose clamp to 80 in-lbs.

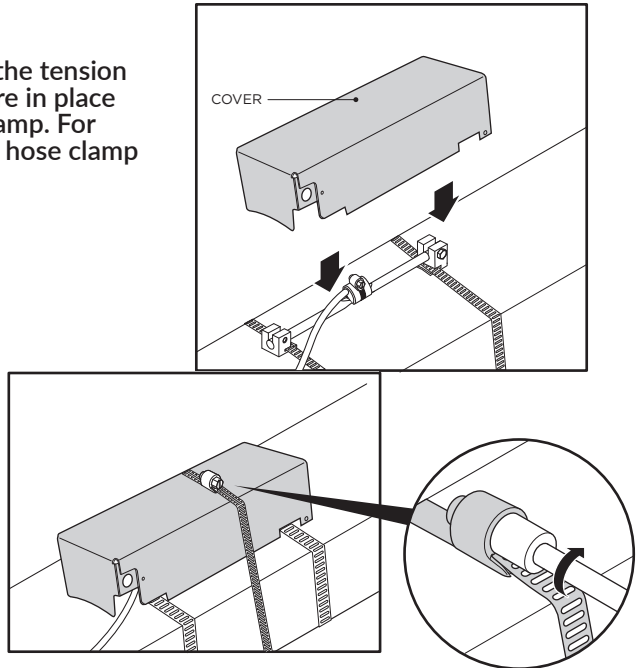

14 INSTALL LOOP CLAMP

Bend the loop clamp over the cable about 4" from the pickup coil.

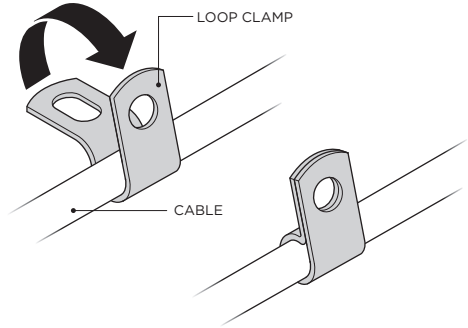

Bolt the loop clamp to the metal cover as shown using the supplied bolt and washer.

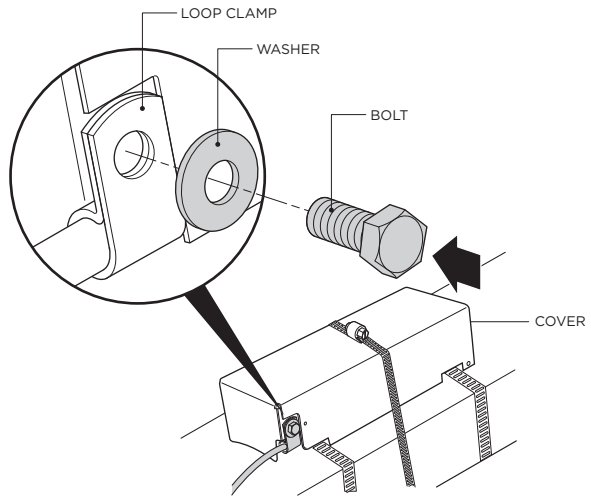

15 CONNECT EXTENSION CABLE AND ROUTE TO GAUGE

Plug the extension cable into the mating connector on the pickup coil cable. Route the other end of the extension cable to the gauge, using the included zip ties to secure the cable along the way. Connect the extension cable to the gauge using the supplied butt connectors. Seal the butt splice connection with the supplied heat shrink tubing. See gauge instructions for further details.

At Right Weigh, we are committed to delivering top-notch products that perform as intended. We stand behind our commitment with confidence. Every new product manufactured or sold by Right Weigh, Inc. is backed by a 3-year warranty from the date of purchase, ensuring freedom from material or manufacturing defects. Within the initial three years of purchase, Right Weigh Inc. will, at its discretion, address product issues by correcting, replacing, or refunding the affected item in accordance with the guidelines outlined in this statement.

Please note that this warranty does not cover product problems resulting from:

1. Improper application, incorrect installation, or operation outside the approved specifications as stated in the product instruction manual.
2. Accidents, faulty suspension parts, or power surges.
3. Inadequate maintenance or repairs.
4. Abuse, misuse, or unauthorized modification.
5. Natural disasters, including but not limited to lightning strikes, floods, fires, earthquakes, etc.

Under this warranty, Right Weigh, Inc.'s liability is limited to the original cost of the product in question and does not extend to labor costs or other expenses related to installation, removal, or replacement of a Right Weigh, Inc. product. Right Weigh, Inc. does not assume responsibility or liability for any loss or damage resulting from the use of our products. Right Weigh, Inc. shall not be liable for direct, indirect, special, incidental, or consequential damages, including loss of profits or loss of time, arising from the performance of a Right Weigh, Inc. product.

We reserve the right to make improvements to product designs, construction, and appearance without prior notice. Additionally, we may discontinue support, warranty, or repair for products that we deem obsolete or for which repair parts are no longer available. No employee or agent of Right Weigh, Inc. has the authority to modify the terms of this warranty without the express written permission of Right Weigh, Inc.

Please contact Right Weigh, Inc. before uninstalling any product suspected of failure. Our support team may engage in troubleshooting efforts to determine if the product is eligible for coverage under this warranty policy. If the product has been uninstalled and troubleshooting cannot be performed, the product in question must be returned to Right Weigh, Inc. for inspection before warranty eligibility can be determined.

To initiate a return, repair, or replacement of a product, you must obtain a Return Merchandise Authorization (RMA) number. This number is required before any product can be returned. Please contact our Customer Service at 503-628-0838 to obtain an RMA number or send an email to rwls@rwls.com.

Third Party extended warranties are not recognized or accepted as valid forms of coverage by Right Weigh, Inc. If you have purchased or obtained an extended warranty from a third-party provider, you must contact the provider for any claims outside of the standard 3-year warranty offered by Right Weigh, Inc. We encourage you to review the terms and conditions of your extended warranty to fully understand its limitations and scope. Right Weigh, Inc. does not extend warranty coverage to any product refurbished by a third-party reseller.



Before returning any product, please obtain a Return Merchandise Authorization (RMA) number by calling customer service at 503-628-0838 or emailing rwls@rwls.com.

Include the RMA number or a printed copy of the RMA with the returned product. Shipping costs for returns must be prepaid by the customer unless otherwise specified by Right Weigh, Inc. Ensure the items are securely packed to prevent damage during shipping and consider insuring against possible damage or loss. Right Weigh, Inc. will not be liable for damages resulting from inadequate or careless packing or loss during transit.

Credit/Refund:

- a. Only applies to new, unused products in their original packaging.
- b. Must be returned within 60 days of original purchase to receive full credit.
- c. New, unused products returned after 60 days from original purchase are subject to a 10% restocking fee.
- d. Returns are not accepted beyond 180 days from original purchase date.

Right Weigh Inc. will issue credit or a refund after evaluating the returned product. Whether the original purchaser receives a credit or refund is at Right Weigh Inc.'s discretion.

Warranty Repair or Replacement

- a. Applies to products with material or manufacturing defect within the period defined by the warranty policy.
- b. Must be able to provide proof of purchase date.
- c. Before uninstalling the product, contact customer service at 503-628-0838 or email rwls@rwls.com for required troubleshooting.

Right Weigh, Inc. will evaluate the returned product(s) at no charge. If the product is determined to be under warranty, it will be repaired or replaced with equivalent product(s).

Right Weigh, Inc. will cover the cost of shipping the warranted product back to the customer using a shipping method of our choosing, equal to or faster than the method used by the customer. For products or parts not covered by warranty, repair or replacement will be done at the customer's expense upon authorization.

We appreciate your understanding and cooperation in adhering to our warranty and return policy. If you have any further questions or require assistance, please don't hesitate to contact our Customer Service at 503-628-0838 or rwls@rwls.com.

THANK YOU FOR YOUR BUSINESS

Thank you for choosing to drive more and scale less! Here at Right Weigh, we are committed to making our products simple to install and easy to use. We understand that installation can vary between vehicles and yours may not be described in this manual. In any event, our technical support team is ready to answer your questions!

SCAN FOR ADDITIONAL RESOURCES



CONTACT US FOR
ADDITIONAL SUPPORT

FOLLOW US!



(503) 628-0838
(888) 818-2058 - Toll Free (USA ONLY)



support@rwls.com



www.rwls.com/manuals-resources/



RightWeighInc



rightweigh_inc



rwlsinc



right-weigh-inc-